

## High sensitivity bipolar Hall switch sensor

### 1.Product Introduction

HK505 is a highly sensitive bipolar Hall switch chip designed based on BCDMOS technology. The chip includes temperature compensation, comparator, and output driver. In addition, mechanical stress has little effect on the magnetic parameters of the chip.

The series of chip sensors is suitable for industrial and automotive applications, with an ambient temperature range of -40 °C to 150 °C and supply voltage range of 2.7V to 30V. AH505 provides a variety of packages to customers: TO92S, SOT23 (small), SOT23. All packages are RoHS compliant. The product has passed AEC-Q100 certification.



### 2.Function

- AEC-Q100 Grade 0 Automotive Level Certification
- Operating Vcc Range:2.7V~30V
- ESD: ±12kV
- high mechanical stress suppression ability
- Temperature range: -40°C~150°C
- The decrease of magnetic flux density caused by rising temperature is compensated by the built-in negative temperature coefficient
- Reverse-voltage protection at Vcc pin
- Suitable for automobiles and industries

### 3.Application

- Speed and RPM sensing
- Tachometer sensor、 Flow-rate sensing
- DC motor, motor and fan control, robotics control
- Proximity sensor、 Position sensor
- Seat belt buckles、 hood/trunk/door latches
- Sunroof/convertible top/tailgate
- liftgate activation
- Brake/clutch pedals
- Electric power steering(EPS)
- Transmission shifting
- Wiper motor

## High sensitivity bipolar Hall switch sensor

---

### 4.Products packaging

Part No.	Packages	temperature range	Packing
HK505UA	T092S	-40°C~150°C	1000pcs/bag
HK505SU	SOT23-3L	-40°C~150°C	3000pcs/reel
HK505SS	SOT23 (small)	-40°C~150°C	3000pcs/reel

### Table of Contents

1.Product Introduction .....	1
2.Function .....	1
3.Application.....	1
4.Products packaging .....	2
5.Functional Block Diagram.....	4
6. Pin information .....	4
7.Absolute Maximum Ratings .....	5
8.Recommended operating conditions.....	5
9.Electrical Parameters .....	6
10.Magnetic Parameters.....	6
11.Magnetic Characteristics.....	6
12.Typical Application Circuit.....	7
13.Characteristic Performance .....	8
14.Package Material Information.....	9
15.Note.....	12
16. Historical Version.....	12

## High sensitivity bipolar Hall switch sensor

### 5. Functional Block Diagram

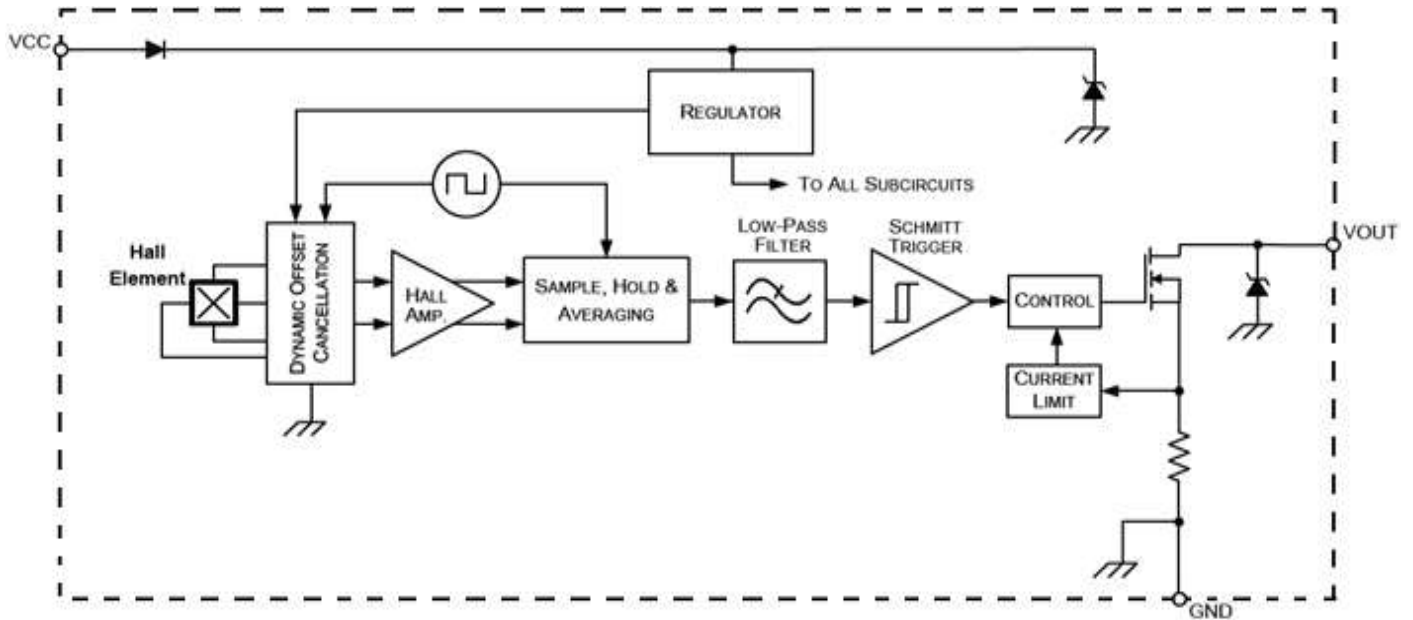

### 6. Pin information

No.	Name	Functions
1	V <sub>CC</sub>	Power supply voltage 2.7V~30V
2	GND	Ground wire
3	V <sub>OUT</sub>	output

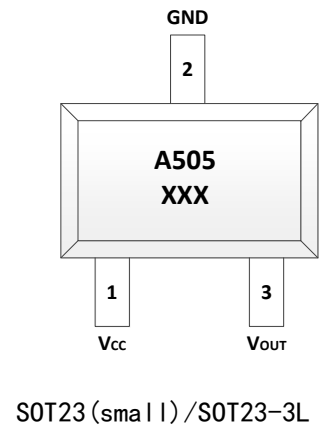
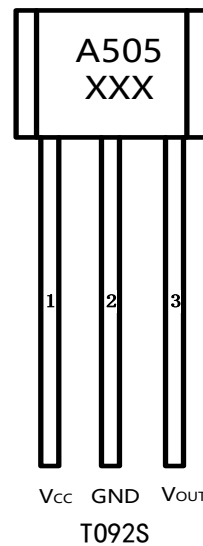

## High sensitivity bipolar Hall switch sensor

### 7. Absolute Maximum Ratings

Absolute maximum ratings are limited values to be applied chips, and beyond which the absolute maximum rating may be damage chips. Although the functionality is not necessarily damaged, exposure to absolute maximum rating conditions for an extended period of time may affect device reliability.

Symbol	Parameters	Pins	Min	Max	Unit	Test condition
V <sub>CC</sub>	supply voltage	1	-20	30	V	t<1000h <sup>1)</sup>
			-	34	V	t<96h <sup>1)</sup>
			-	36	V	t<5min <sup>1)</sup>
V <sub>OUT</sub>	Output voltage	3	-0.5	30	V	t<1000h <sup>1)</sup>
			-	34	V	t<96h <sup>1)</sup>
			-	36	V	t<5min <sup>1)</sup>
I <sub>O</sub>	Output current	3	-	65	mA	-
I <sub>OR</sub>	Reverse output current	3	50	-	mA	-
T <sub>A</sub>	operating ambient temperature	-	-40	170	°C	t<96h <sup>1)</sup>

<sup>1)</sup> No accumulated stress

### 8. Recommended operating conditions

When the operation of the chip exceeds the range described in the recommended operating conditions, it may lead to abnormal chip operation and may reduce reliability and service life

Symbol	Parameters	Pins	Min	Typ	Max	Unit
V <sub>CC</sub>	supply voltage	1	2.7	-	30	V
T <sub>A</sub>	operating ambient temperature	-	-40	-	150	°C
V <sub>OUT</sub>	Output voltage	3	-	-	30	V
I <sub>OUT</sub>	Output current	3	-	-	25	mA

### ESD ratings

Symbol	Describe	Executive standards	Max	Unit
V <sub>ESD</sub>	HBM	JEDEC JS-001-2017	12	kV

## High sensitivity bipolar Hall switch sensor

### 9. Electrical Parameters

Test conditions:  $V_{CC}=2.7V\sim 30V$ ,  $T_A=-40^{\circ}C\sim 150^{\circ}C$

Symbol	Parameters	Pins	Min	Typ	Max	Unit	Test condition
power supply $V_{CC}=12V$							
$I_{CC}$	Power supply current	1	-	2.5	3.2	mA	3-wire
$I_{CCR}$	reverse current	-	-	-	1	mA	$V_{CC}=-18V$
Output							
$V_{OL}$	Low output voltage	3	-	0.13	0.4	V	$I_O=20mA$
			-	-	0.5	V	$I_O=25mA$
$T_F$	Output Fall Time	-	-	-	1	$\mu s$	$R_L=82\Omega$ $C_L=20pF$
$T_R$	Output Rise Time	-	-	-	1	$\mu s$	
$B_{NOISE}$	Effective noise of magnetic switching points	-	-	1	-	Gs	Suitable for square wave signals of 1kHz
$T_J$	Output Jitter	-	-	-	0.5	$\mu s$	Suitable for square wave signals of 1kHz
$T_D$	delay time	-	-	16	-	$\mu s$	-
$T_{SAMP}$	Output	-	1.6	2	2.66	$\mu s$	-

### 10. Magnetic Parameters

Part No.	Switch Type	TC(pp m/K)	Bop (Gs)			Brp (Gs)			BHYS (Gs)		
			Min	Typ	Max	Min	Typ	Max	Min	Typ	Max
HK505	Bipolar	-1000	-	133	-	-	-133	-	-	266	-

### 11. Magnetic Characteristics

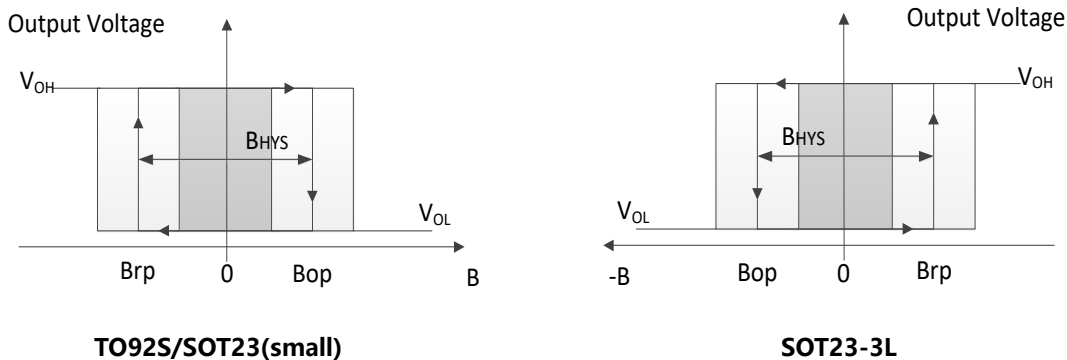

## High sensitivity bipolar Hall switch sensor

### 12. Typical Application Circuit

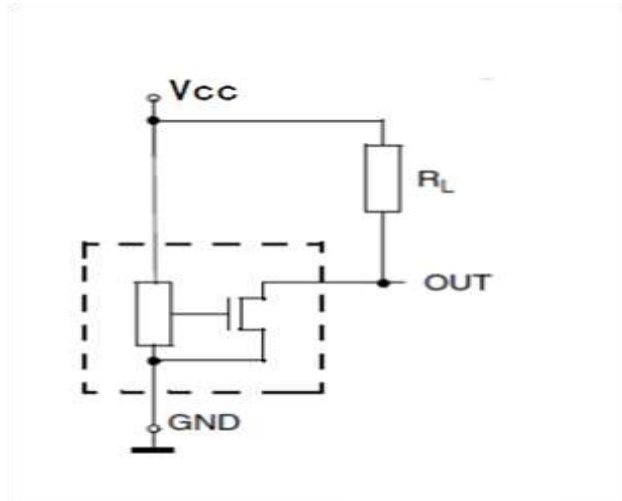

Typical Application Circuit 1

For applications with interference or radiation interference on the supply line, a series resistor  $R_V$  and two capacitors  $C_P$  and  $C_L$  are placed near the sensor (typical application circuit 2). For example:  $R_V=100\ \Omega$ ,  $C_P=10\text{nF}$  and  $C_L=4.7\text{nF}$ .  $R_L$  is an open drain pull-up resistor, which must be placed near the input end of the host controller to enable wire break detection.

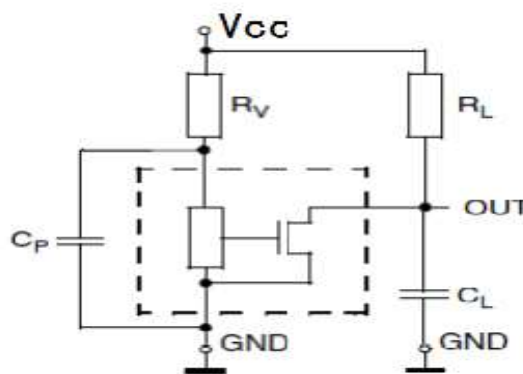

Typical Application Circuit 2

## High sensitivity bipolar Hall switch sensor

### 13.Characteristic Performance

$V_{cc}=5V$ , Bop and Brp Characteristic Performance

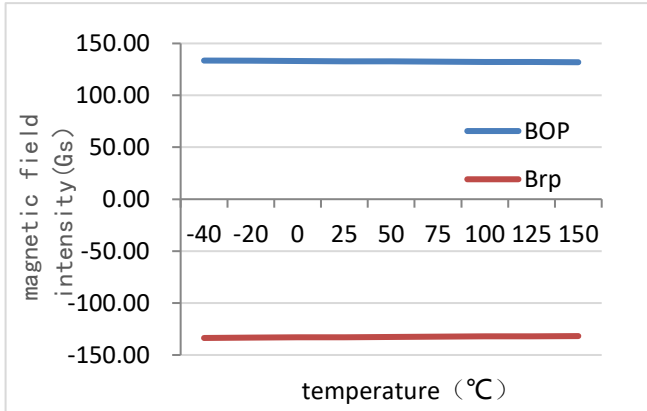

$V_{cc}=5V$ , Bop and Brp Characteristic Performance

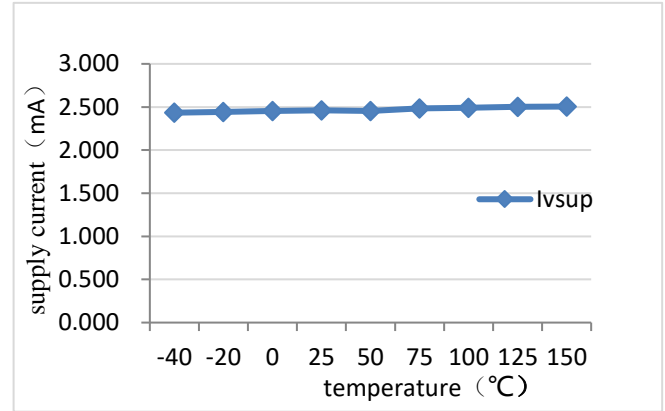

Different temperature and supply voltage, Supply current Characteristic Performance

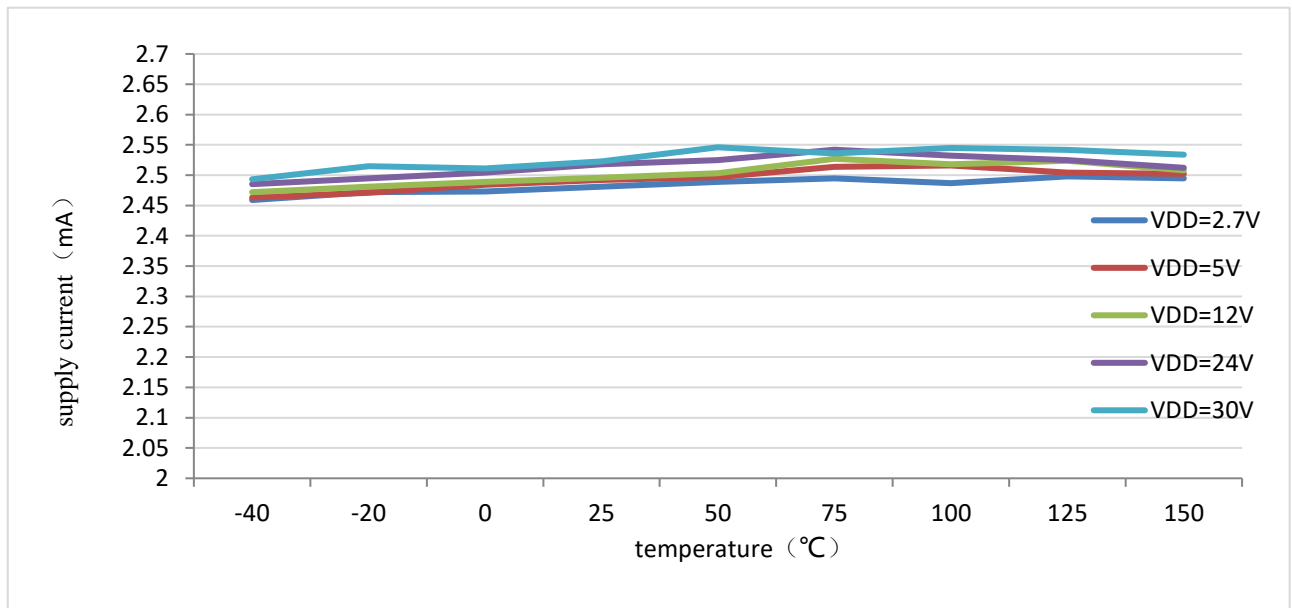



## High sensitivity bipolar Hall switch sensor

### 14.Package Material Information

#### TO92S Package Size

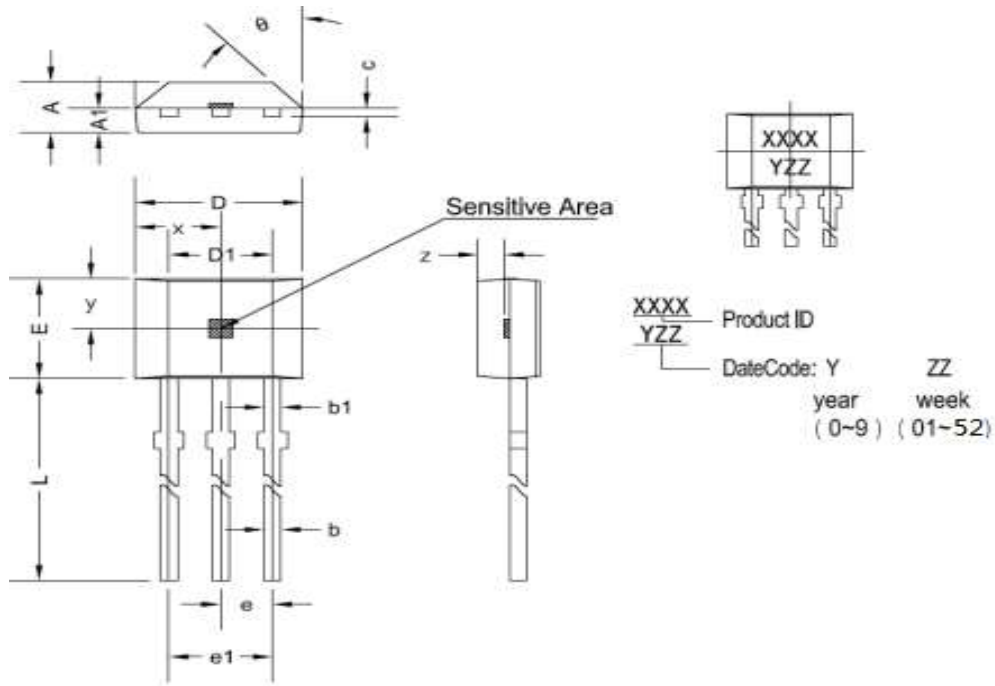

Symbol	Dimensions in Millimeters		Dimensions in Inches	
	Min	Max	Min	Max
A	1.420	1.620	0.056	0.064
A1	0.660	0.860	0.026	0.034
b	0.350	0.560	0.014	0.022
b1	0.420TYP		0.016TYP	
C	0.360	0.510	0.014	0.020
D	3.900	4.100	0.154	0.162
D1	2.970	3.270	0.117	0.129
E	2.900	3.100	0.114	0.122
e	1.270TYP		0.050TYP	
e1	2.540TYP		0.100TYP	
L	15.500	16.200	0.610	0.638
x	2.025TYP		0.080TYP	
y	1.545TYP		0.061TYP	
z	0.500TYP		0.020TYP	
theta	45°TYP		45°TYP	

## High sensitivity bipolar Hall switch sensor

### SOT23-3L Package Size

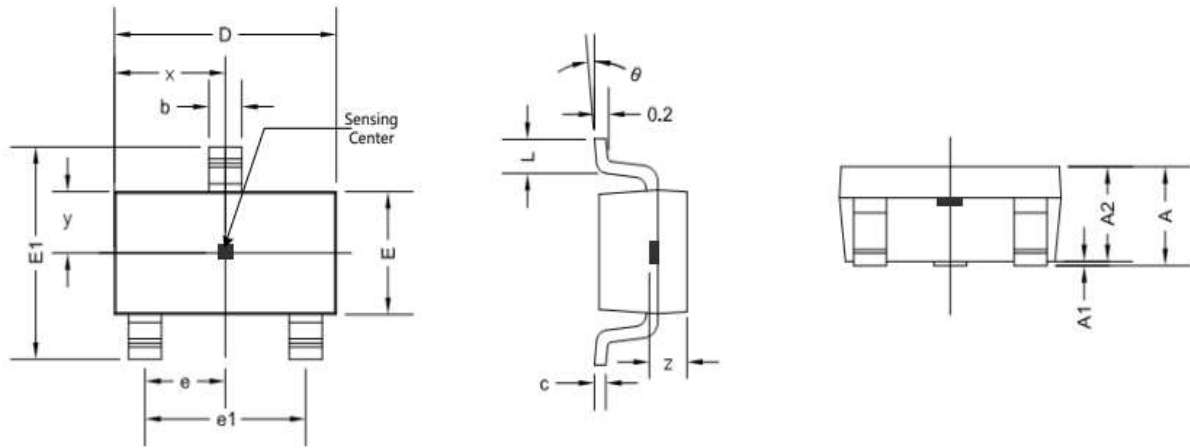

Symbol	Dimensions in Millimeters		Dimensions in Inches	
	Min	Max	Min	Max
A	1.050	1.300	0.041	0.051
A1	0.000	0.150	0.000	0.006
A2	1.000	1.200	0.039	0.047
b	0.300	0.500	0.012	0.020
c	0.080	0.220	0.003	0.009
D	2.800	3.020	0.110	0.119
E	1.500	1.700	0.059	0.067
E1	2.600	3.000	0.102	0.118
e	0.950TYP		0.037TYP	
e1	1.800	2.000	0.071	0.079
L	0.300	0.600	0.012	0.024
x	1.460TYP		0.057TYP	
y	0.800TYP		0.032TYP	
z	0.600TYP		0.024TYP	
θ	0°	8°	0°	8°

## High sensitivity bipolar Hall switch sensor

### SOT23 (small) Package Size

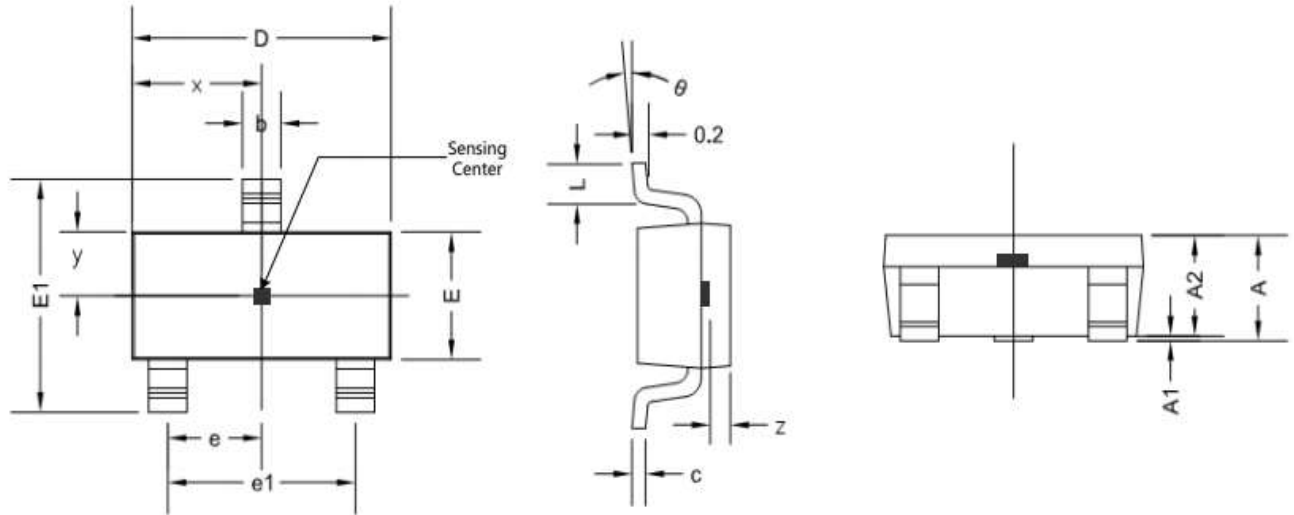

Symbol	Dimensions in Millimeters		Dimensions in Inches	
	Min	Max	Min	Max
A	0.900	1.150	0.035	0.045
A1	0.000	0.100	0.000	0.004
A2	0.900	1.100	0.035	0.043
b	0.300	0.500	0.012	0.020
c	0.132	0.202	0.005	0.008
D	2.800	3.000	0.110	0.118
E	1.200	1.400	0.047	0.055
E1	2.250	2.550	0.089	0.100
e	0.950TYP		0.037TYP	
e1	1.800	2.000	0.071	0.079
L	0.300	0.500	0.012	0.020
x	1.460TYP		0.057TYP	
y	0.650TYP		0.026TYP	
z	0.500TYP		0.020TYP	
$\theta$	0°	8°	0°	8°

## High sensitivity bipolar Hall switch sensor

---

### 15.Note

- Hall chips are sensitive devices, and electrostatic protection measures should be taken during use, installation, and storage.
- During installation and use, mechanical stress applied to the device casing and leads should be minimized as much as possible.
- It is recommended that the welding temperature should not exceed 350 °C and the duration should not exceed 5 seconds.
- To ensure the safety and stability of Hall chips, it is not recommended to use them beyond the parameter range for a long time.

### 16. Historical Version

No.	Time	Describe
1	September 6th, 2022	Update Characteristic Performance.
2	December 22th, 2022	Update static voltage output error range
3	February 9th, 2023	Update IC limit of operate temperature and storage temperature
4	April 19th, 2023	Version update to V1.2