

Low power omnipolar hall sensor

Introduction

HK466M is designed and produced using CMOS technology. It is a south pole and north pole sensitive low-power omnipolar Hall effect switch. The device integrates a voltage regulator, a Hall voltage generator, a small signal amplifier, a chopper regulator, and schmitt-trigger and push-pull output. The sensor has the characteristics of good temperature stability, strong stress resistance and high sensitivity, and its operating voltage is 2.0-5.5V.

HK466M provides TO-92S in-line package and SOT23-3L package. Both packages meet ROHS environmental protection standards.

Features

- Micro-power battery-powered applications
- – Highest ESD performance up to $\pm 6\text{kV}$
- Omnipolar output switch
- Push-pull output
- Operating voltage 2.0-5.5V

application

- Solid state switch
- Cordless mobile phone reminder switch
- Flip phone screen saver switch
- Proximity switch
- Magnetic sensor switch with low duty cycle instead of reed
- Level gauge

Package



Low power omnipolar hall sensor

Ordering Information

Partnumber	package	Packing	Ambient, TA
HK466MUA	TO92S	Bulk, 1000 pieces/bag	-40°C to 85°C
HK466MSU	SOT23-3L	Reel, 3000pieces/reel	-40°C to 85°C

Limit parameters

The limit parameter is the limit value when the chip is applied. Exceeding the limit value may damage the chip. Although the function of the chip is not necessarily damaged when the limit parameter is exceeded, if the limit value is exceeded within a certain period of time, the reliability of the chip may be affected.

Parameter	Symbol	Value	Units
Supply voltage	VDD	6.0	V
Reverse voltage	VDD	-0.3	V
Output Sink Current	I _{sink}	5	mA
Output Voltage	V _{out}	6.0	V
Operating temperature range	T _a	-40~85	°C
Storage temperature range	T _s	-50~150	°C

Electrical and magnetic characteristics (T_a =25°C , VDD = 2.7V)

Parameter	Symbol	Test Conditions	Min	Typ	Max	Units
Electrical characteristics						
Operating voltage	VDD		2.0		5.5	V
Output low voltage	VOL	I _{out} =1mA			0.2	V
Output high voltage	VOH	I _{out} =1mA	VDD-0.2			V
Supply current	IDD			5	10	uA
Wake-up mode time	T _{wake}	working		20		us
Sleep mode time	T _{period}	working		20		ms
workingfrequency				50		Hz

Low power omnipolar hall sensor

response frequency			50			Hz
Magnetic characteristics						
Operate point	Bop	B > BopS (B < BopN) , Vout On	+/-9	+/-18	+/-27	Gauss
Release point	Brp	B < BopS (B > opN) , Vout Off	+/-3	+/-12	+/-21	Gauss
Hysteresis	Bhys	Bop-Brp	6			Gauss

Function diagram

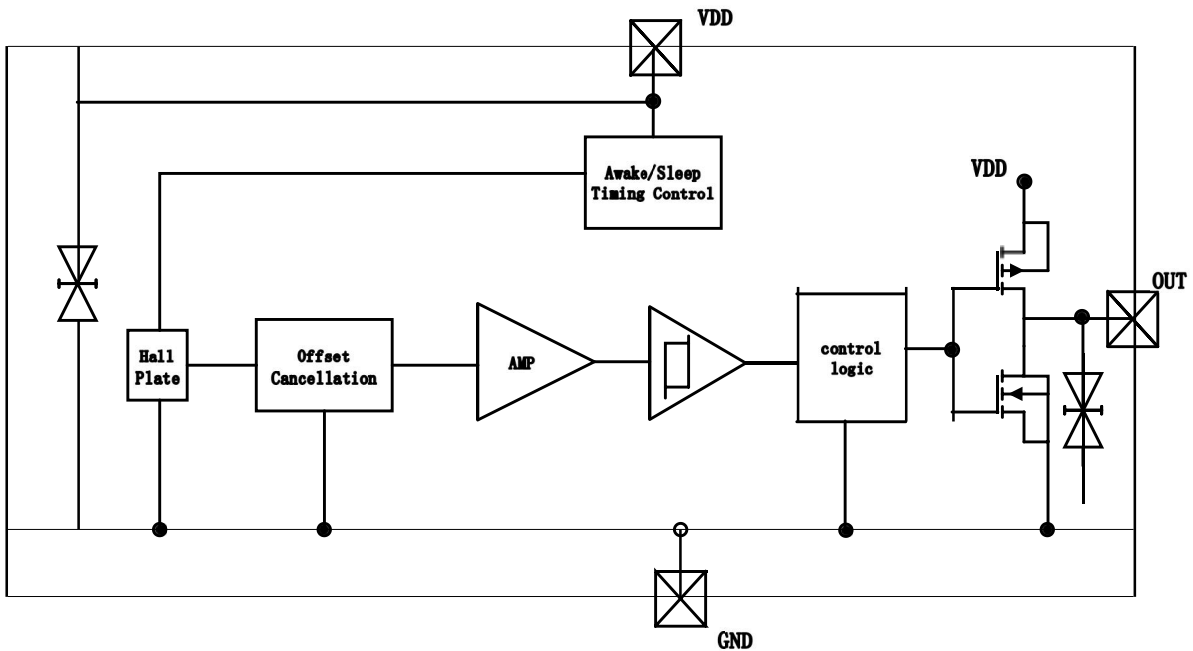

Pin Description



TO92S

TO92S

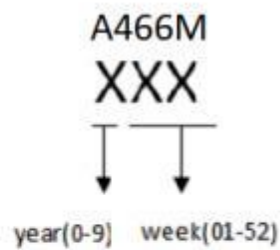

SOT23

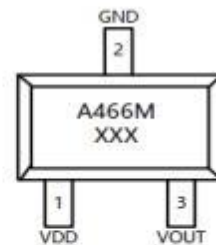

SOT23

Low power omnipolar hall sensor

applicationexample

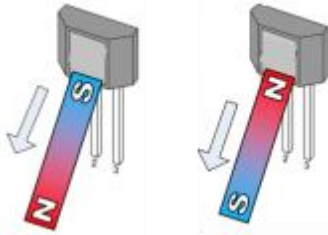

VOUT= High

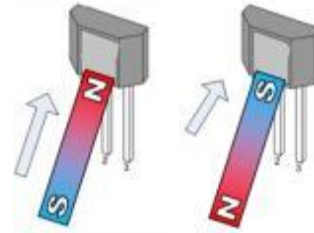

VOUT= Low

TO92S (HK466MUA)

TO92S 引脚说明

Name	Pin number	Description
VDD	1	Power supply
Vout	2	Ground
GND	3	Output

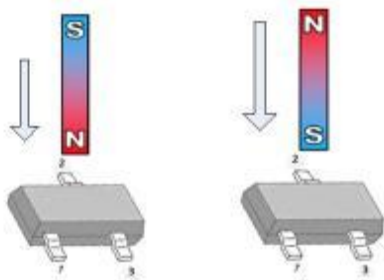

VOUT= Low

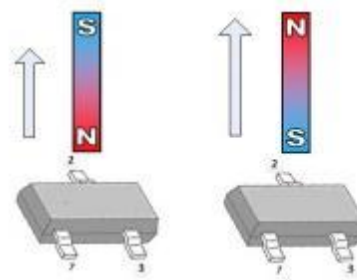

VOUT= High

SOT23 (HK466MSU)

SOT23 Pin description

Name	Pin number	Description
VDD	1	Power supply
Vout	2	Output
GND	3	Ground

Low power omnipolar hall sensor

Output Behavior

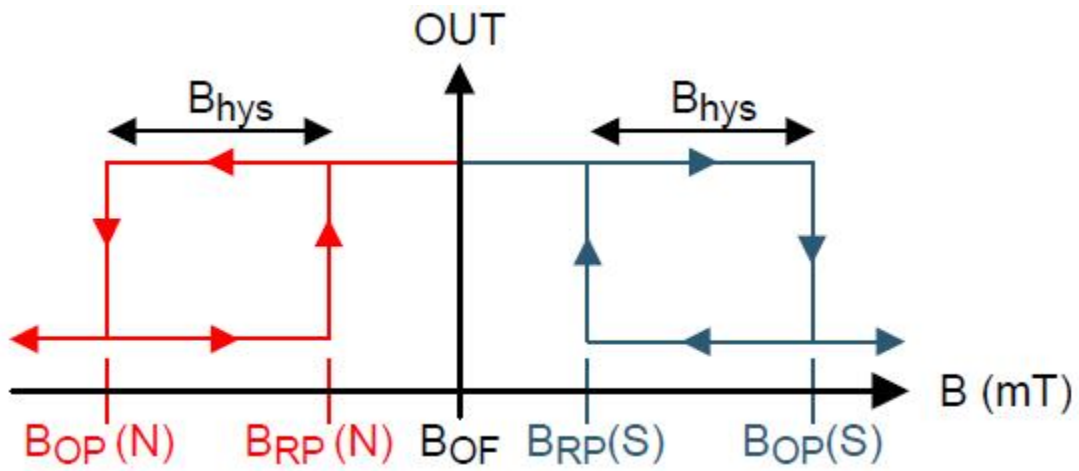

Application Circuits

C1=10nF , C2=100pF

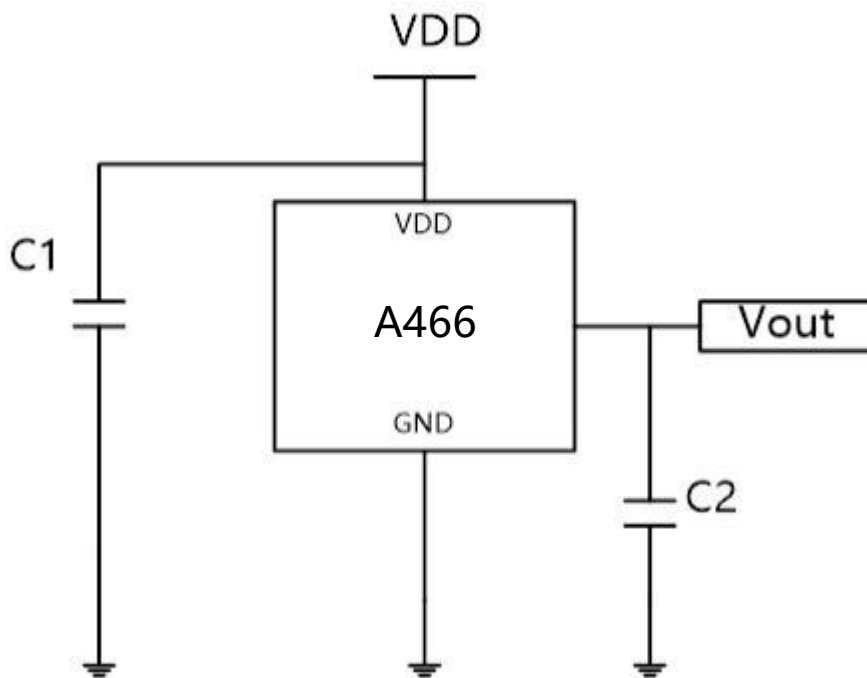

typical application circuit

Low power omnipolar hall sensor

Package dimensions

TO92S

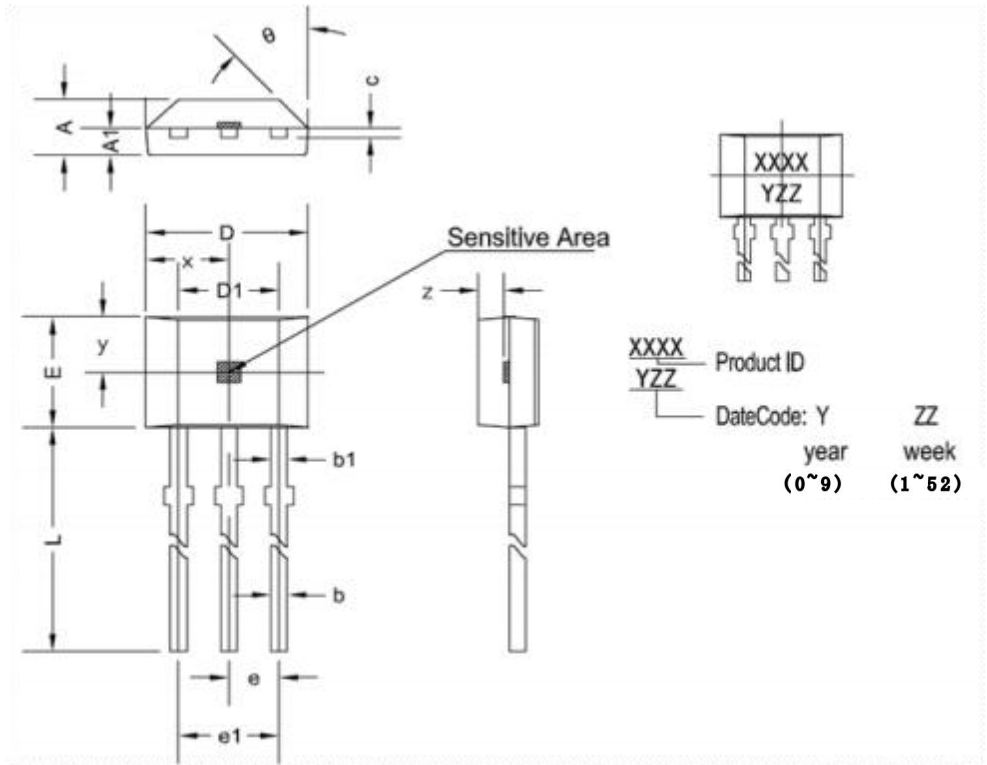

TO92S dimensions

symbol	Size (mm)		Size (in inches)	
	minimum	maximum	minimum	maximum
A	1.42	1.67	0.056	0.066
A1	0.66	0.86	0.026	0.034
b	0.35	0.56	0.014	0.022
b1	0.4	0.55	0.016	0.022
C	0.36	0.51	0.014	0.02
D	3.9	4.2	0.154	0.165
D1	2.97	3.27	0.117	0.129
E	2.9	3.28	0.114	0.129
e	1.270 TYP		0.050 TYP	
e1	2.44	2.64	0.096	0.104
L	13.5	15.5	0.531	0.61
x	2.025 TYP		0.080 TYP	
y	1.545 TYP		0.061 TYP	
z	0.500 TYP		0.020 TYP	
θ	45° TYP		45° TYP	